

Mercury TP-702

Innovative High Speed Strapping Machine

TP-702 is an innovative world-class high speed automatic strapping machine. It is suitable for 5 mm, 6 mm, 9 mm, or 12 mm PP strapping. Equipping with all industry's standard features and creative user friendly designs, Mercury TP-702 offers the most optimal performance, highest speed, easiest maintenance, and the most cost effective solution in its class.

TP-702-59



TP-702-12



Main Features



Robust and Compact Strapping Head

Use the latest brushless DC motor direct drive technology to provide the highest level of accuracy and reliability. All motors are German-made. Without belts, clutches, and pulleys, its compact design greatly minimizes the numbers of moving parts and maintenance cost.



Free Access to Strap Guides (patents registered)

Hinged top plate makes easy access to the strapping head for quick maintenance. Unblocking the guides enables free and quick access to strap guides without using any tools. The most maintenance friendly design.



Waist-High Auto Strap Feeding

Friendly design to feed the strap automatically from the upper side of the coil without the need to access to the bottom of the machine.



Waist-High Quick Coil Change (patents registered)

Innovative waist-high coil change without access to the bottom of the machine. Quick release lock reduces downtime to change the coil. Ergonomic and quick change design makes coil change simpler than ever.

More Features

Sensor Controlled Heater

The fast heating mechanism is sensor controlled assuring consistent and high sealing efficiency.

Low Voltage

All DC motors and heater are "stepped down" to 24V to increase the safety of the machine.

Strap End Ejector

Eject the end of strap from the inlet of strap feeding. Easy to clean the end of strap and get the machine ready for next coil of strap.

Front Foot Bar Switch

Standard front foot bar switch makes machine operation in a very easy way. Ergonomic cycle initiation design and user friendly.

Dispenser Release Switch

Friendly design makes it easier to pull the strap from the strap dispenser for waist-high auto strap feeding.

Adjustable Table Height

The table height is adjustable to any height between 820 mm and 920 mm.

Turnable Operating Control Panel

The turnable operating control panel with LCD display is located on upper side of the machine for easy access. It enables machine operation from both front and rear sides. User friendly.

Auto Strap Ejector

Loop-ejector clears unwanted strap automatically if the machine is accidentally activated without a package.

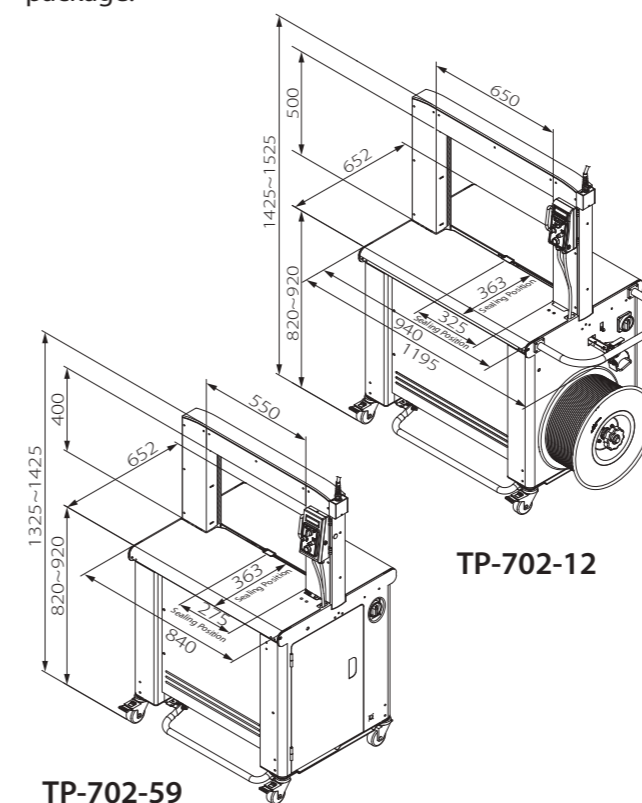

Options

- Photo-eye switch
- Rear foot bar switch
- Foot pedal switch
- Lower adjustable table height (770 mm - 820 mm)
- Selected parts in stainless steel
- Stainless steel frame SUS 304 (TP-702S-59, TP-702S-12)

Arch Sizes

TP-702-59 (for 5 mm, 6 mm, or 9 mm strap)

H \ W	550	650	850	1050	1250	1650	1850
400	Ⓢ		✓				
500		✓	✓	✓	✓	✓	
600			✓				
800			✓	✓	✓		✓
1000				✓	✓		

Ⓢ Standard size : 550 mm (W) x 400 mm (H)

- ✓ means available arch size

TP-702-12 (for 12 mm strap)

H \ W	650	850	1050	1250	1650	1850	2050	2250
400		✓						
500	Ⓢ		✓		✓		✓	
600		✓	✓	✓				✓
800		✓	✓	✓		✓		
1000		✓	✓	✓				
1200			✓	✓	✓			

Ⓢ Standard size : 650 mm (W) x 500 mm (H)

- ✓ means available arch size

Technical Data

Capacity	Up to 65 cycles/minute (TP-702-59) Up to 60 cycles/minute (TP-702-12)
Strap Width	5 mm, 6 mm, or 9 mm (TP-702-59) 12 mm (TP-702-12)
Tension Range	1 - 32 kg (TP-702-59) 1 - 45 kg (TP-702-12) (Higher tension is on request)
Weight	158 kg (TP-702-59), 167 kg (TP-702-12)
Electrical Requirements	110V, 220V, 230V, 240V 50/60Hz 1PH