

ProWrap F/A

The new automatic pallet wrapping solution
for automated lines and increased performance



FULLY AUTOMATIC TURNABLE STRECH WRAPPING MACHINES

100%
MADE in ITALY

The new **SIAT ProWrap F/A** turntable wrapping machine is completely **automatic, adaptable, and scalable** for intensive and demanding stretch film applications. It can optimise and radically reduce film consumption and ensure total control over all wrapping parameters throughout the entire cycle. This machine can handle any type of pallet up to 2.000 kg and is intended for medium and high-demand wrapping applications.

With the **ProWrap F/A**, you can position the conveyor at a 90° angle and choose from a variety of infeed and outfeed choices, while the integrated roller conveyor with narrow pitch rollers ensures safe and smooth movement of all types of pallets.

AUTOMATE YOUR LINE AND INCREASE YOUR PERFORMANCES

ProWrap F/A features a state-of-the-art Viking PW™ motorized carriage for a 250% pre-stretch kit as standard and the ability to go up to 350% with an additional pre-stretch kit. Easy Film Insertion (No Thread®).

The machines also include, as standard, clamping, cutting, and brushing units for end-of-cycle stretch film treatment. This is done easily through a single arm that performs both cutting and brushing.

SPECIFICATIONS

Turntables configuration	1710 mm (1000x1200)	/ 1990 mm (1200x1400)
Column heights	2200 mm	/ 3000 mm
Carriages	Fixed pre-stretch up to 300% (Viking PW, PWT)	/ Variable pre-stretch up to 400% (Viking DM)
Power supply	400V 3ph+N+T (50/60Hz)	/ 480V 3ph+T (60Hz)
Programs	up to 20	
Capacity production	up to 35 pallet/hour	

OPTIONS

- » Film welding system
- » Roping
- » Pressing unit
- » 90° film recovery system
- » Safety fences

FULL CONTROL OF YOUR WRAPPING



The ProWrap F/A range models are equipped with PLC and touchscreen HMI for more intuitive control and advanced features.

Through the touchscreen, a range of statistics can be displayed including cycles started and cycles completed, and meters of film used, in order to optimize consumption and generate less waste. Each data item is displayed by a total counter and a resettable partial counter.

Recipes used to optimize wrapping are also recordable while diagnostics and alarms are also searchable.

FEATURES & BENEFITS

- » Ideal for end of line – and demanding applications
- » New design – with long-lasting structure
- » 7" color touch screen control panel – to check the status of the machine and its consumption
- » Easy-to-use – with the possibility of configuring the machine on the field
- » Flexible – available in 2 base/column configurations
- » Film welding system – present in the arm lever that allows the film tail to be welded to the pallet when finished (available on request)
- » 250% pre-stretch as standard
- » Possibility of reaching 350% with an addition pre-stretch kit



Machine dimensions

Dimensioni macchina
 Maschinenabmessungen
 Dimensions machine
 Dimensiones de máquina

	Column L	Column H
H	3007 mm	3804 mm
TOR	min 360 max 700 mm	
L	2850	
D	1710 or 1990	

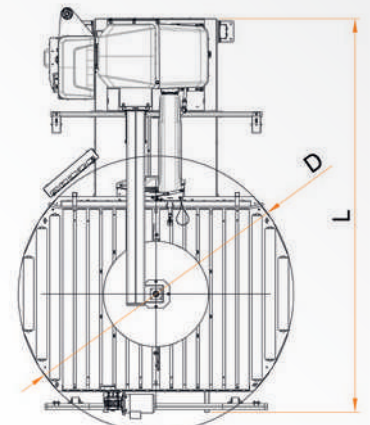
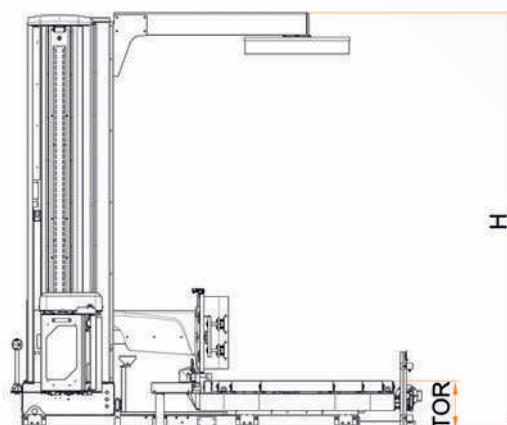

The SIAT Group



Headquartered in Northern Italy, SIAT is established as a quality leader in end-of-line industrial packaging solutions, specializing in taping, strapping and wrapping machines, as well as flexographic printing machines.

Based in Ohio (USA), Combi is a Northern American producer of industrial packaging systems, engineering and manufacturing case erectors, tray formers, case sealers, case packers, robotic packaging systems, and ergonomic monoblock hand-packing stations.



Located in Northern Italy, Tam has been producing small metal parts and providing precision machining services for over 30 years.

For over 50 years, we have been manufacturing high-tech equipment and are proud to be recognized by our customers as among the leading brands in packaging machinery and components. Our solutions are utilized across various industries, including food and beverage, e-commerce, logistics, packaging, and consumer products.

Our machines are designed to:



Increase customer productivity

Our machines boast an average life of 25 years, while our customers pay off their investment in only 4 to 5 months.

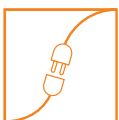

Lower the total cost of ownership

Our machines are designed for easy maintenance and simple installation. They are developed to be user-friendly and durable, while also being easy to integrate and manage.



Reduce environmental impact

We strongly believe in pursuing this goal through our environmental approach, envisioning the future of packaging as a collaborative effort with our customers to find the most sustainable and secure solutions. Each machine is designed to consume less energy, minimize material usage, and reduce waste.



Be connected

Thanks to Optirun, the SIAT Group's IoT solutions brand, we can calculate tape and box consumption, monitor film usage, and track all machine parameters to prevent downtime.



E-commerce

Buy directly at www.shop.siat.com



Service

Contact our field service Team at servicenow@siat.com



Via Puecher 22,
22078 Turate - Como
www.siat.com

